

MISC. WINDOW HARDWARE

154-2 BUMPER STOP

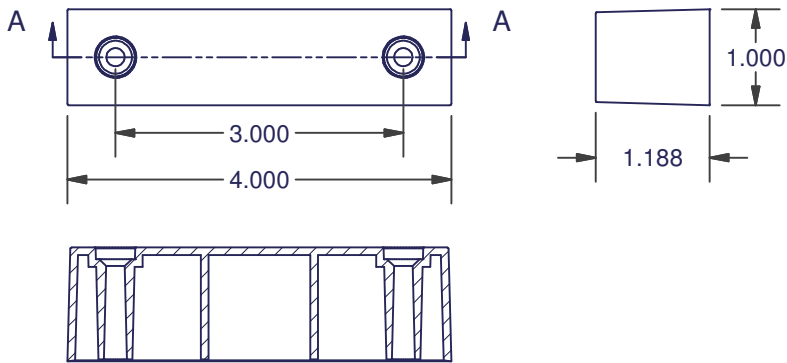

SECTION A-A

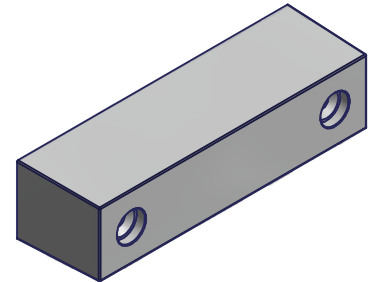

MATERIAL: NYLON
COLOR: BLACK

158-8 FEMALE FASTENER

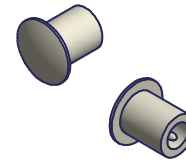
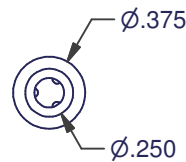
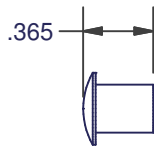

MATERIAL: NYLON
COLOR: NATURAL

159-2 SPACER

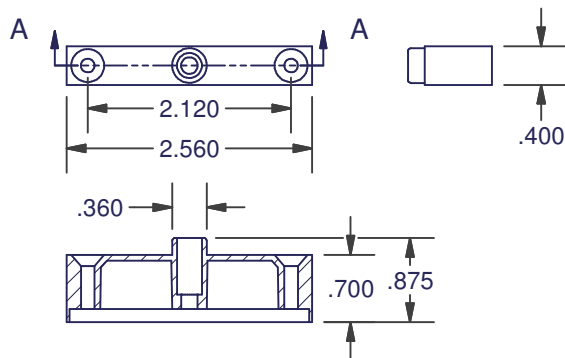

SECTION A-A

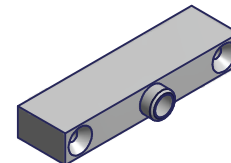

MATERIAL: ABS
COLOR: BLACK

DIMENSIONS ARE FOR REFERENCE ONLY AND ARE IN INCHES UNLESS OTHERWISE NOTED.
CONTACT OUR ENGINEERING DEPARTMENT WITH SPECIFIC APPLICATION QUESTIONS OR REQUIREMENTS.
NOT ALL COMBINATIONS LISTED ARE CURRENTLY STOCKED, EXTRA LEAD TIME MAY BE REQUIRED.