

SLIDING DOOR ROLLERS

QUOTE REQUEST INFORMATION:

- _____ = DOORS PER YEAR FORECAST
- _____ = HOUSING MATERIAL
- _____ = W/ SPRING (Y OR N)
- _____ = OVERALL WIDTH
- _____ = WHEEL DIA.

1939 SERIES
END ADJUST TANDEM AXLE
 BOX QTY: 50

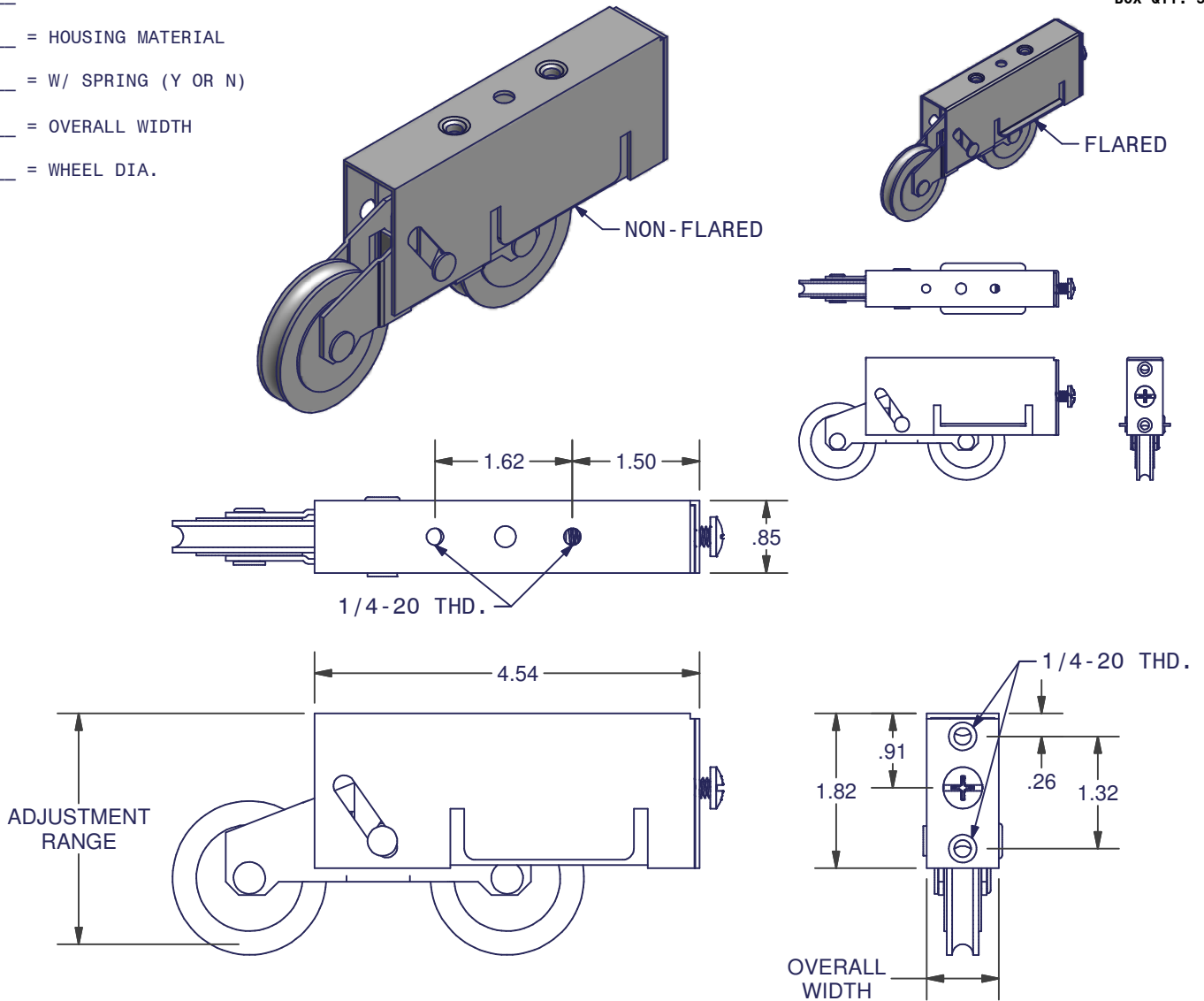

HOUSING MATERIAL	ZINC PLATED SPRING	FLARED	OVERALL WIDTH	WHEEL DIA.	ADJUSTMENT RANGE	BEARING MATERIAL
S	YES	NO	0.85	1.81	2.03-2.69	S
	YES	YES	1.15			
	NO	YES	1.15			
SS	YES	NO	0.85	1.50	1.88-2.53	SS
	NO	YES	1.08			
	NO	YES	.095			

LEGEND			
CODE	DESCRIPTION	CODE	DESCRIPTION
TBN	NYLON WHEEL W/ STEEL BEARING	S	MILD STEEL W/ YZD PLATING WHEEL & BEARING
BNSS	NYLON WHEEL W/ STAINLESS STEEL BEARING	PST	STEEL WHEEL W/ PRECISION BEARING
PRN	NYLON WHEEL W/ PRECISION BEARING	SS	STAINLESS STEEL WHEEL & BEARING
		PRS	STAINLESS STEEL WHEEL W/ PRECISION BEARING

DIMENSIONS ARE FOR REFERENCE ONLY AND ARE IN INCHES UNLESS OTHERWISE NOTED.
 CONTACT OUR ENGINEERING DEPARTMENT WITH SPECIFIC APPLICATION QUESTIONS OR REQUIREMENTS.
 NOT ALL COMBINATIONS LISTED ARE CURRENTLY STOCKED, EXTRA LEAD TIME MAY BE REQUIRED.