

REV	DESCRIPTION	DATE	ECO#	BY
1	CHANGED STIFFENER	2/25/00	N/A	BJV
2	CHANGED STRIPES	9/11/00	N/A	BJV
3	CHANGED STIFFENER TO NO NOTCH	10/20/00	N/A	BJV
4	CHANGED STIFFENER TO NOTCH	7/23/01	N/A	BJV
5	CHANGED PRINT TO REFLECT PART PRODUCED	8/29/01	N/A	BJV
6	SEE ECN	7/26/02	030-02	BJV
7	SEE ECN	5/20/03	198-03	BJV
8	SEE ECN	6/23/11	101-11	JN
9	REMOVED TOOLING FROM PROD PAGE	11/29/16	121-109	JN
10	ADDED ADOBE COLOR BATCH MIX	8/8/18	498-109	JN

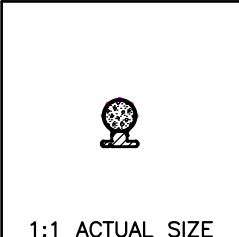

REFER TO CAD DRAWING FOR ALL DIMENSIONS NOT FULLY CONSTRAINED. 1:1 ACTUAL SIZE

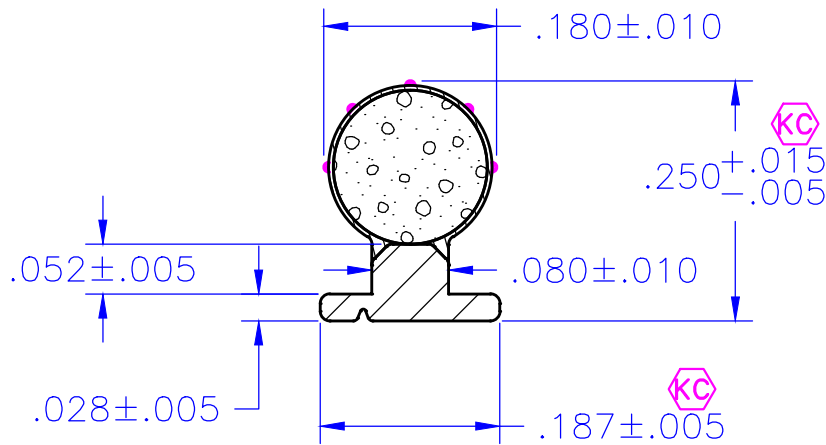

INTERPRET PER: SAME Y14.5M-2009		DRAWING TITLE: <b>.187 X .250 T-SLOT</b>	
UNITS: INCH		DRAWN BY: <b>BJV</b> CHECKED BY: <b>DA</b>	
TOLERANCE UNLESS OTHERWISE SPECIFIED		SCALE: <b>5:1</b> SHEET: <b>1 OF 3</b>	
1 PL ± .100 2 PL ± .010 3 PL ± .005 ANGULAR TOL ± 1°		CAD TYPE: <b>AUTOCAD</b>	SIZE: <b>A</b>
		DRAWING #: <b>32401</b>	REV: <b>10</b>

THE INFORMATION CONTAINED IN THIS DRAWING IS CONFIDENTIAL AND PROPRIETARY. THIS DRAWING IS NOT TO BE COPIED OR REPRODUCED IN WHOLE OR IN PART WITHOUT EXPRESS WRITTEN CONSENT.

